

SNOW MELTING AND ICE PREVENTION of roads and ramps

THE APPLICATION

Duty

Snow melting and ice prevention of roads, ramps, paths, walkways, stairways, etc. comprises two discrete duties:

- **Snow melting** requires high powers, typically 300W/m² for perhaps only 50 hours per year;
- **Ice prevention** requires a lower “idling” load of say 0 to 150W/m² much more frequently, typically 2000 hours per year.

Objective

To minimise operating costs by ensuring that only the correct (and small) proportion of the installed load is delivered to prevent ice formation.

The Need for Energy Management

The large electrical installed loads of snow melting applications have potential for tremendous energy wastage unless effective energy management is employed.

ON/OFF control commonly applies the full installed load at all times when snow falls or cold temperatures occur. **65–90% of consumed power is likely to be wasted.**

It is a fact that many ill-conceived snowmelting installations are permanently disconnected after the user has experienced one winter’s operating costs.

Such wastage equates to **\$140/m² at average industrial tariffs when costs of an efficient system need be little more than \$5/m².**

Summary of Potential Benefits

ENERGY Savings can be enormous. Efficient control of a ramp 6m wide by 100m long may save \$25000/yr.

MAXIMUM DEMAND may be significantly reduced.

HEATER LIFE is increased if power is applied incrementally rather than by on/off thermal cycling.



NOTE Estimated energy savings and other data based on average UK winter conditions.

SMALL INSTALLATIONS

Heating Cables

Convenient parallel resistance self-regulating (eg. *SnoMelt*) or constant power (eg. *Snowflow*) are chosen, both of which can be cut to length at site.

Damage to parallel cables is local and repairable. If a circuit is severed, for example during road maintenance, the circuit will continue to operate fully if connected from both cable ends whereas a series cable fails completely.

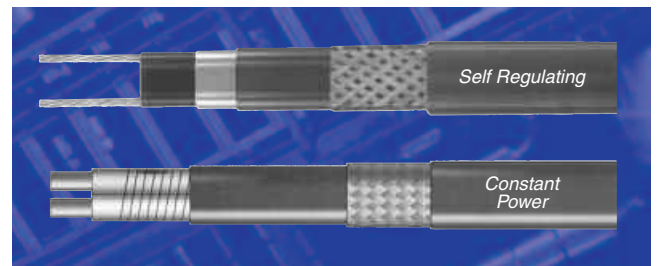

Control

Minimum control (LEVEL 1) comprises a seasonal switch (eg. *Durastat*) set at say, 3°C which fully energises the installed load whenever the ambient temperature falls below set point. There is no recognition of snow or moisture presence or surface temperature.

However, even for installations as small as 10m², consideration should be given to the provision of dual level power controls with surface temperature and snow and moisture presence recognition (LEVEL 2). Full power is applied when snow falls and a reduced fixed power is applied when surface temperatures approach freezing point.

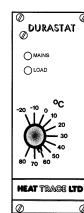

LEVEL 1 CONTROL
Ambient temperature sensing

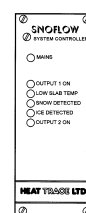

LEVEL 2 CONTROL
Dual Power
- high power for snow melting
- lower power for ice prevention

ENERGY SAVINGS
65–90%

Payback

A LEVEL 2 dual power control system (eg. *Snowflow* Controller) will reduce operating costs compared with ambient temperature control (LEVEL 1) only, by over 70%. Additional capital costs will be recovered within 2 years for installations of only 15m² based on a 300W/m² installed load.

SNOW MELTING AND ICE PREVENTION of roads and ramps

LARGE INSTALLATIONS

For installations over 75m², consideration should be given to self-regulating power control (modulation) of the lower idling mode of 'LEVEL 2' control to reduce operating costs to the lowest possible level.

Self-regulation is achieved by *Powermatching*.

Heating cables

For Powermatching, heaters should be normally constant wattage, either parallel resistance (eg. *Snowflow*), or when long circuits are needed, series resistance type (eg. *Longline*).

Powermatch Control

A *Powermatch* is programmed to self-regulate the power to always deliver precisely the amount of heat to prevent freezing and will virtually eliminate wastage.

Payback

LEVEL 3 *Powermatch* control reduces operating costs by approximately 80% compared with LEVEL 1, and over 55% compared with LEVEL 2 control.

Additional capital costs will be recovered within 2 years for installations of only 100m² based on a 300W/m² installed load.

Circuit Health Monitoring

Snow melting systems typically spend 10 months of the year switched off. Year round circuit monitoring and alarm is possible with a *Powermatch* self-regulated system.

LEVEL 3 CONTROL AND MONITORING

Heat Trace have developed a comprehensive snow melting and ice prevention control system incorporating *Powermatch* which handles the ice prevention duty by monitoring the air temperature, and supplies only the correct small proportion of the installed load during freezing conditions.

A main *Snowflow* control unit applies full power if it snows.

Powermatch and *Snowflow* combine to produce the most energy efficient snow melting/ice prevention control system available.

A *Watchdog* circuit health monitor is usually incorporated to supply an alarm signal in the event of damage to the normally constant power heaters.

A *Temperature Display Unit* may be employed to display the concrete surface temperature.

Small systems may be driven by solid state relays. However, many snow melting installations comprise high power loads which are driven by thyristor stacks via Heat Trace's *Interpulse* interface units.

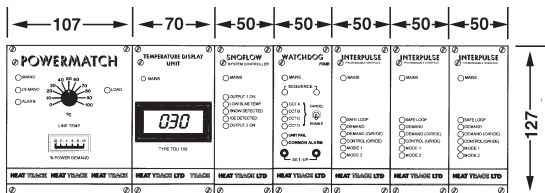

PANEL FASCIA
(dimensions in mm)

INSTALLATION EXAMPLE

Large installation with 'LEVEL 3' control, circuit health monitoring and temperature readout.

Snow melting and ice prevention to a concrete ramp.

Ramp dimensions 6m x 100m long. Area = 600m²

Installed Load 300W/m² (180kW)

Supply 415V 3ph (60kW/ph = 250A/ph)

Min. ambient temp. -15°C

Maximum idling

(ice prevention) load 0.5 x installed load (150W/m²)

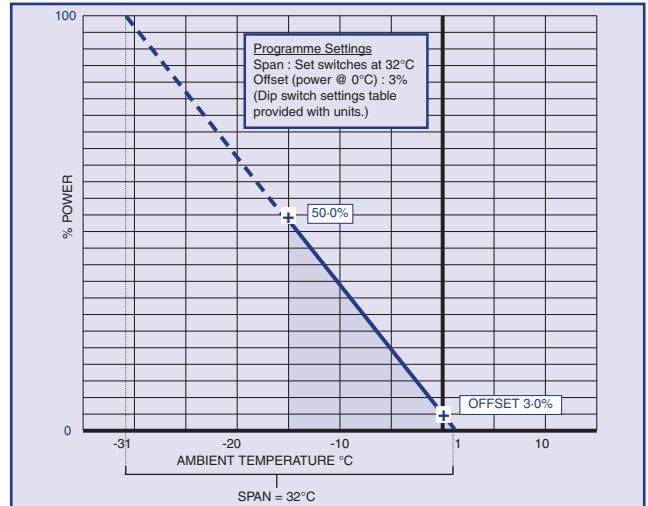

TYPICAL CONTROL ARRANGEMENT

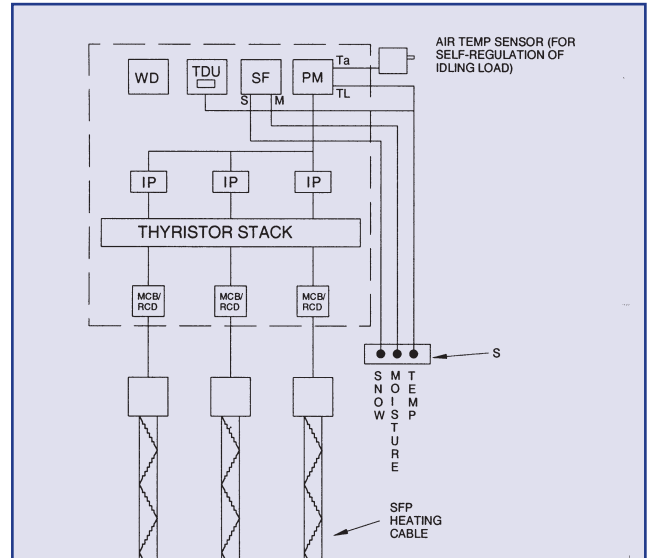

KEY		
WD	Watchdog circuit health monitor	CPDS070
PM	Powermatch self-regulating controller	CPDS030
SF	Snowflow Controller	CPDS140
S	Snowflow Sensor	N/A
TDU	Temperature display unit	CPDS050
IP	Interpulse drive interface unit	CPDS040
SFP	Snowflow heating cable	HPDS190



Mere's Edge, Chester Road, Helsby, Frodsham, Cheshire, WA6 0DJ, UK.
Tel: +44 (0)1928 726 451 Fax: +44 (0)1928 727 846 www.heat-trace.com

The information given herein, including drawings, illustrations and schematics (which are intended for illustration purposes only), is believed to be reliable. However, Heat Trace Ltd makes no warranties as to its accuracy or completeness and disclaims any liability in connection with its use. Users of Heat Trace Ltd products should make their own evaluation to determine the suitability of each such product for specific applications. In no way will Heat Trace Ltd be liable for any damages arising out of the misuse, resale or use of the product.