

# HEAT TRACING OF LONG BURIED PIPELINES

## THE APPLICATION

### Installed Loads

Heat losses from a buried pipe remain substantially constant. A designer will propose an installed load having excess heat capacity as he must anticipate worst ground conditions which may never actually prevail.

Unless controlled, this excess heat could result in system failure or reliability problems.

### Electrical Supplies

Often the most important consideration when heating long pipelines is the number and location of electrical supplies. They are normally available only at the pipe ends. The cost of providing intermediate supplies is prohibitive, so heating circuits must be designed for long route lengths.

### The Need for Power/Energy Management

Long pipelines typically require hundreds of kilowatts to maintain pumpable temperatures. Power/Energy management minimises operating costs, maximum demand and eliminates expansion/contraction which could result in failure of the thermal insulation or heater.

### Reliability

Single heating circuits can be run multi-kilometres with circuit failure rendering the complete pipeline useless. Reliability is therefore crucial when heated pipes are buried.

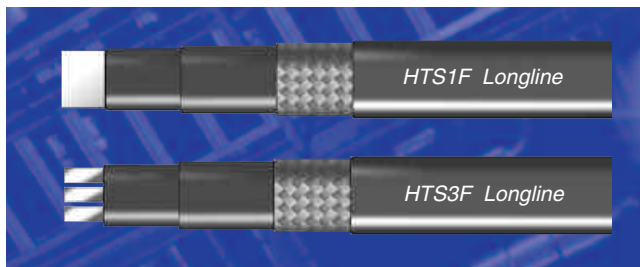

## HEATING CABLES

Low resistance conductors, 3 phase star connected produce long circuits. Conductor sizes and applied voltage are adjusted to provide the required length and output.

A single *Longline HTS3F* tracer having 3 conductors is suitable for shorter circuits (up to, say, 1km). Multiple large single conductor *Longline HTS1F* tracer cater for longer circuits (up to, say, 5km).

Compared with round conductors, flat foils are outstandingly thermally efficient due to their large surface area and they are much more flexible.

## CONTROL

Temperature control of a buried pipeline should be accurate to attempt to eliminate the expansion and contraction and the system stresses that this creates.

### Conventional Control

Long heated pipelines are usually controlled by a line thermostat operating a large contactor having a limited life – a 20 minute ON/OFF switching cycle may result in contact failure in less than two years.

To extend contactor life, the thermostat switch differential is often widened to reduce the switching frequency. This produces poor efficiency under no flow conditions. When the product flows, energy wastage is 100% because the controller switch off temperature is never reached and so the load remains permanently energised.

ON/OFF thermal cycling of the piping and its system eventually results in, at best, damage to the thermal insulation system and possible system failure.

For a high integrity long pipeline installation, this form of control is inappropriate.

### PowerTrim Control

Powertrimming is a technique to reduce the installed load to the point where thermal balance is reached – heater output almost exactly compensates for heat losses.

Powertrimming during commissioning minimises expansion/contraction and energy wastage. High accuracy electronic line controls are then used simply to fine tune the now barely oversized load.



# HEAT TRACING OF LONG BURIED PIPELINES

## INSTALLATION EXAMPLE

### Design Parameters

24" x 5000m long crude oil buried pipeline.	
Electrical feeds	at ends of pipe
Burial depth	1m minimum
Ground conditions	Sandy, wet
Average soil temp at 1m	+10°C
Maintain temperature	60°C
Insulation	50mm polyurethane foam
Installed load	66W/m pipe (3 x 22W/m heaters)
System voltage	600V 3 phase

### System Component Selection

The system comprises 2 x 2500m circuits. Each circuit consists of 3 series resistance *Longline* heating cables straight traced to the pipeline, each producing 22W/m when connected to a 600V 3 phase supply.

Control of the system comprises a *Centurion* proportional temperature controller having high and low temperature alarms, *Interpulse* interface units with multi-programmable output modes for PowerTrimming and a 3 phase thyristor stack rated for the load.

The pipeline temperature is monitored. If it falls to a low alarm setting, the normal power trimmed output mode from the *Interpulse* units is automatically switched to high power mode to heat the line back to its desired level before returning to the lower power trimmed output mode.

The health of the heating cables is monitored by a *Watchdog* circuit monitor. Circuit damage will produce an alarm signal before the line temperature can fall and give an opportunity to correct damage before a process problem can arise.

### Commissioning

During commissioning, the *Interpulse* interface units were programmed for 100% power for the heat raise mode. The load was backed off until heater output almost matched the heat losses in maintaining the required 60°C. Actual losses were found to be 51W/m or 77% of installed load. The PowerTrimmed output mode of the *Interpulse* units were programmed for 80% power. The marginal excess load was then controlled by the *Centurion* fine tune proportional controller.

### Summary

The installed system is capable of maintaining a highly accurate line temperature which will vary only if products are introduced into the line at temperatures other than design values.

The heaters will deliver only the amount of heat required without thermal cycling. Heater life expectancy would be virtually infinite. Energy consumption/operating costs and maximum demand are minimised.

## TYPICAL INSTALLATION

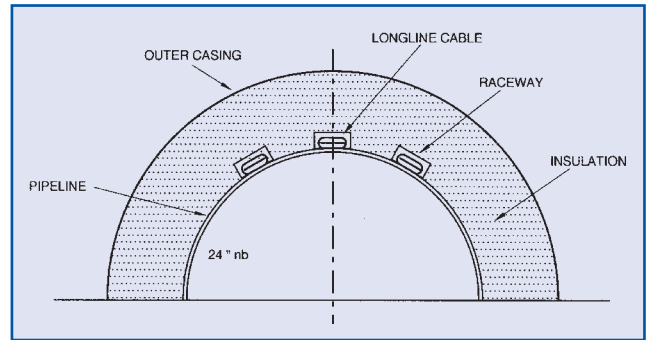

## TYPICAL CONTROL ARRANGEMENT

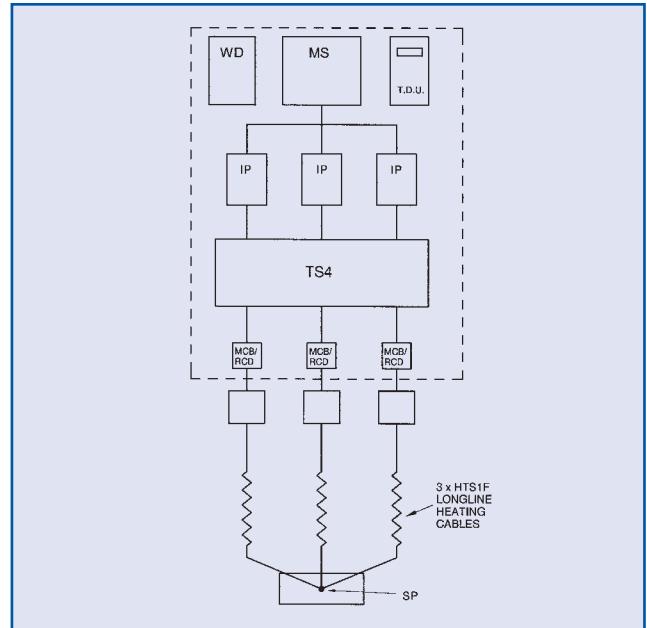

## PANEL FASCIA (dimensions in mm)

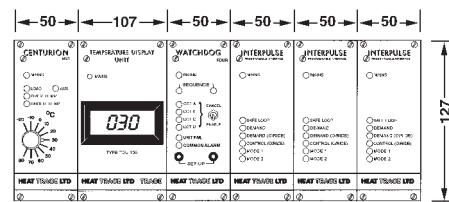

## KEY

HTS1F	Longline heating cables	HPDS143
WD	Watchdog circuit health monitor	CPDS070
MS	Centurion controller	CPDS100
TDU	Temperature display unit	CPDS050
IP	Interpulse drive interface unit	CPDS040
TS4	Thyristor stack	CPDS130
SP	Star point	N/A



Mere's Edge, Chester Road, Helsby, Frodsham, Cheshire, WA6 0DJ, UK.  
Tel: +44 (0)1928 726 451 Fax: +44 (0)1928 727 846 www.heat-trace.com

The information given herein, including drawings, illustrations and schematics (which are intended for illustration purposes only), is believed to be reliable. However, Heat Trace Ltd makes no warranties as to its accuracy or completeness and disclaims any liability in connection with its use. Users of Heat Trace Ltd products should make their own evaluation to determine the suitability of each such product for specific applications. In no way will Heat Trace Ltd be liable for any damages arising out of the misuse, resale or use of the product.